



Taming the Panther

WARNING! HANDLE WITH CARE
 Sailcloth, if misused, can be susceptible to puncture and UV damage. Always rig and de-rig on smooth surfaces and avoid direct sunlight exposure when your sail is not in use.

A Setting the Downhaul and Outhaul:

Adjust the downhaul and the outhaul together. That means, the more you downhaul, the more you outhaul. And, the less you downhaul, the less you outhaul. Use the color coded downhaul dots printed on the leech between battens #2 and #3 along with the color coded outhaul cords at the clew.

Light Wind (red dots)	1) Downhaul until the looseness extends to the red dots on the leech.	2) Set boom length to the red cord.	3) Outhaul to the end of the boom.
Medium Wind (black dots)	1) Downhaul until the looseness extends to the black dots on the leech.	2) Set boom length to the black cord.	3) Outhaul to the end of the boom.
Strong Wind (white dots)	1) Downhaul until the looseness extends to the white dots on the leech.	2) Set boom length to the white cord.	3) Outhaul to the end of the boom.

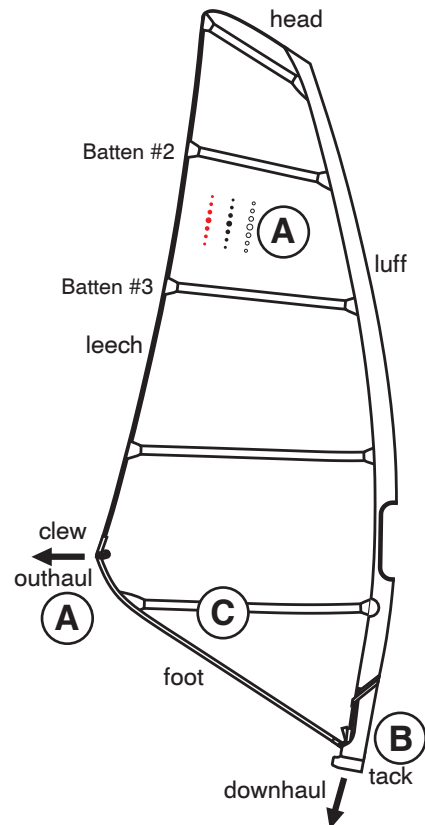

Note: You can set your downhaul with the boom on or off of the sail.

Hint: In order to see the looseness on the upper leech, bounce the upper leech up and down off of the ground.

Note: The leech looseness should not extend beyond the high-wind dots. If you are still overpowered, apply more outhaul, or switch to a smaller sail.

B Tension the foot with the tack strap:

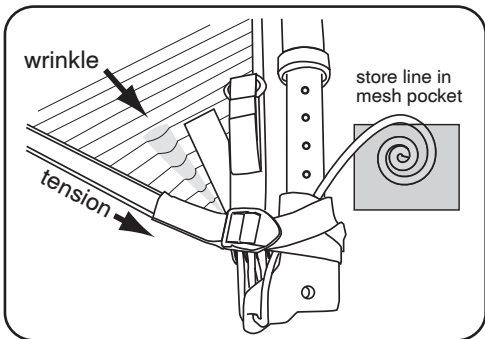

After downhauling, thread the tack strap through the buckle and tension the strap until the foot gets tension. You will see a small wrinkle running out from the corner of the sail. Then, wrap the end of the tack strap around your mast extension and loop the end of the tack strap under itself and secure the strap with the velcro. Store your downhaul line in the mesh pocket located inside the pad.

C Batten Tension:

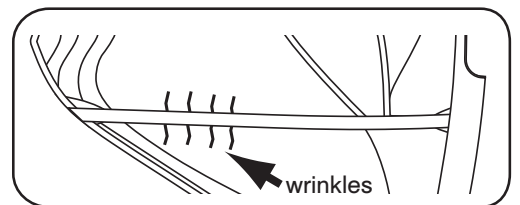

Use the tensioner key that is stored at the tack of the sail and tension the battens until you eliminate any vertical wrinkles that extend out from either side of the batten pocket.

Note: Your battens have already been tuned by us in the factory and most likely will not need further tuning. Be careful not to over-tension your battens.

Common Questions:

Which is best: to rig to the downhaul and outhaul specs. printed on the sail or, to use the downhaul indicators and the clew cords?

It is best to use the downhaul indicators and the clew cords. The downhaul and outhaul lengths will vary between different mast brands. However, when used on the suggested Ezzy mast, the printed specs. will be accurate.

Why do I need so much positive outhaul for high wind sailing?

Unlike rotational sails, Ezzy sails are designed with profile built into the sail panels. You must use the outhaul to flatten the profile when setting for stronger wind conditions.

What can I do to make my sail last longer?

- 1) Don't rig on sharp objects.
- 2) When you are not sailing, store your sail in the shade away from direct sunlight.
- 3) Try not to crease your sail while rigging and de-rigging and
- 4) If you store your sail vertically, make sure it is sleeve-end down. This prevents the leech from being damaged.

Do I need to rinse my sail with fresh water after sailing?

No.

What do I do with the pad when rolling the sail?

After rolling the sail, tuck the pad so it rests along the sail, wrap the tack strap around the pad and the sail, then attach the velcro (figure 1).

Which end of the sail goes into the bag first?

If you store your sail vertically, it is better to have the sail resting on the sleeve rather than the clew, therefore insert your sail with the sleeve-end first into the bag (figure 2).

My vinyl window has turned hazy blue and is now hard to see through, what should I do?

This happens when you roll your sail up wet with fresh water. Once it dries, it will go back to being clear.

What's the best way to clean my window?

The vinyl window can be cleaned with fresh water and a dry towel.

Problem Solving:

I get jerked forward while sailing.

This can be caused by too little downhaul or a mast that is too stiff in the top. It may also help to move your mast base further back in your mast track.

My sail feels too powerful.

Sail is too full. Try more outhaul and possibly more downhaul.

My sail doesn't feel stable when sailing.

Sail is too full. Try more outhaul and possibly more downhaul.

I need more power.

Sail is too flat. Try less outhaul and possibly less downhaul.

My sail pulls too much on my back arm.

Try more outhaul and possibly less downhaul. Try moving your harness lines further back.

My sail pulls too much on my front arm.

Try less outhaul and possibly more downhaul. Try moving your harness lines further forward.

Ezzy Mast:

Does the Ezzy Panther only work on Ezzy Skinny Masts?

No. The Panther was designed to work on both skinny and regular diameter masts.

What is the advantage of using a skinny mast?

They are stronger, lighter and easier to maneuver.

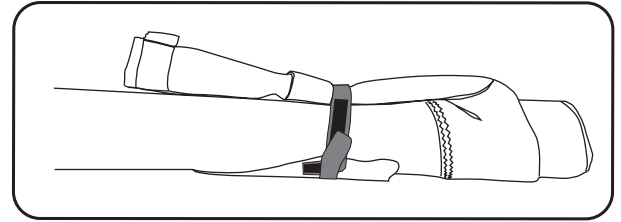

(figure 1)

After rolling, wrap the tack strap around the pad and sail.



(figure 2)

To avoid damaging your sail, insert the sail sleeve-end first into the bag.

SAIL	340 Top	340 Base	370 Top	370 Base	400 Top	400 Base	430 Top	430 Base	460 Top	460 Base
2.9	x	x								
3.3	x	x								
3.5	x	x								
3.7		x	x							
4.0			x	x						
4.2			x	x						
4.5				x	x					
4.7					x	x				
5.0					x	x				
5.2					x	x				
5.5						x	x			
5.8							x	x		
6.0							x	x		
6.3							x	x		
6.9									x	x

x = best combination
 = good combination

(figure 3)

Suggested Masts

rigging videos: www.ezzy.com

email: info@ezzy.com