

Freewave Tuning

(2009)

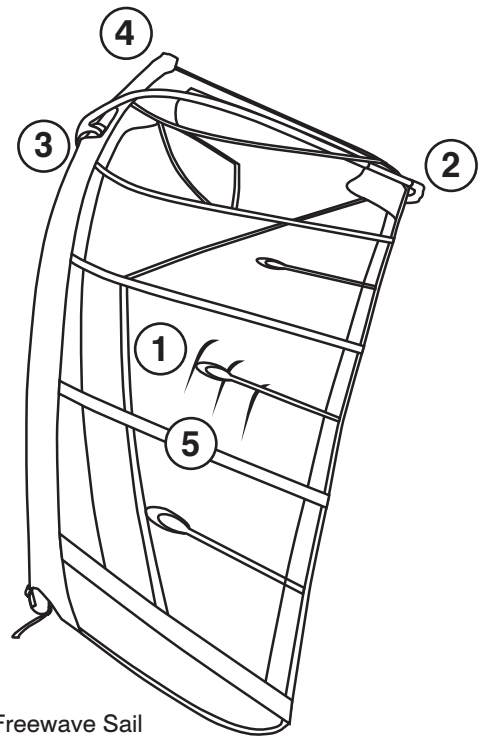

Freewave Sail
(view from head)

1 Downhaul Indicators:

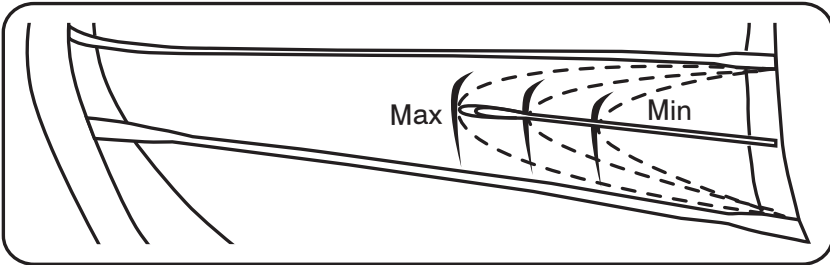

To set your downhaul, use the three bars that are printed between battens #2 and #3. For strong wind, downhaul until the leech goes loose to the bar closest to the mast. For medium wind, the looseness should extend to the middle bar and for light wind the looseness will extend to the bar closest to the leech.

2 Outhaul for light to strong wind:

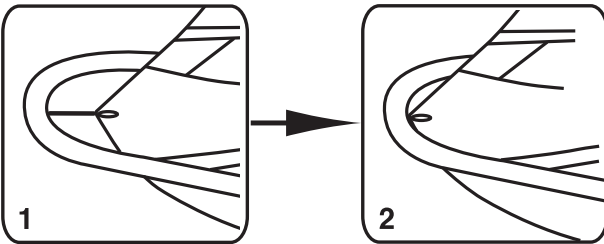

1) With your sail correctly downhauled, adjust your boom length as follows: Hold the sail's clew-cord straight out and adjust the boom-end to meet it (use the short cord for light wind, medium cord for medium wind and long cord for strong wind).

2) Now that your boom is set to the correct length, outhaul the sail to the end of the boom.

4 Tack Strap, tighten it and wrap it:

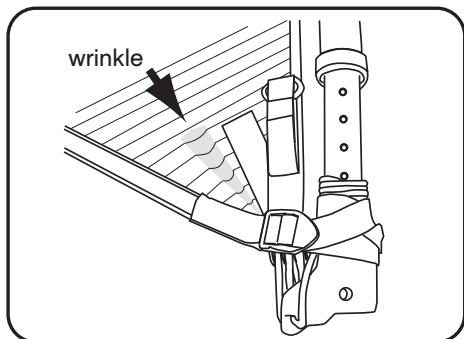

Wrap your downhaul line around the mast base. Thread the tack strap through the buckle and tension until you get a small wrinkle running out from the corner of the sail. Wrap the end of the tack strap around your mast extension and loop the end of the tack strap under itself and secure the strap with the velcro.

3 Batten cross-section view:

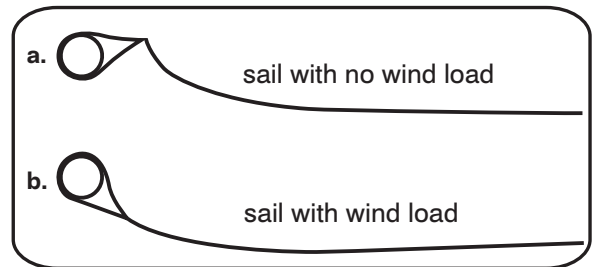

When unloaded, the cross-section of the batten above the boom will look like diagram (a). Loaded with wind, it will look like diagram (b).

5 Batten Tension:

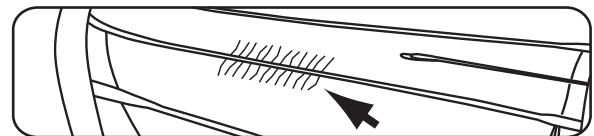

Use the tensioner key that is stored at the tack of the sail and tension the battens until you eliminate any vertical wrinkles that extend out from either side of the batten pocket.

Common Questions:

Why do I need a lot of positive outhaul for high wind sailing?

The Freewave has been designed with shape built into the seams. If you don't outhaul enough, the sail will be too deep and hard to control in strong wind.

What can I do to make my sail last longer?

1) When you are not sailing, store your sail in the shade away from direct sunlight.
2) Try not to crease your sail while rigging and de-rigging and 3) if you store your sail vertically, make sure it is sleeve-end down. This prevents the leech from being damaged.

Do I need to rinse my sail with fresh water after sailing?

No.

Do I need to dry my sail before rolling it up?

No

What do I do with the pad when rolling the sail?

After rolling the sail, tuck the pad so it rests along the sail, wrap the tack strap around the pad and the sail, then attach the velcro (figure 1).

Which end of the sail goes into the bag first?

To avoid wrinkling the clew, always insert your sail with the sleeve-end first into the bag (figure 2).

My vinyl window has turned hazy blue and is now hard to see through, what should I do?

This happens when you roll your sail up wet with fresh water. Once it dries, it will go back to being clear.

What's the best way to clean my window?

The vinyl window can be cleaned with fresh water and a dry towel.

Problem Solving:

I get jerked forward while sailing.

This can be caused by too little downhaul or a mast that is too stiff in the top. It may also help to move your mast further back on your board.

My sail feels too powerful.

Sail is too full. Try more outhaul and possibly more downhaul.

My sail doesn't feel stable when sailing.

Sail is too full. Try more outhaul and possibly more downhaul.

I need more power.

Sail is too flat. Try less outhaul and possibly less downhaul.

My sail pulls too much on my back arm.

Try more outhaul and possibly less downhaul. Try moving your harness lines further back.

My sail pulls too much on my front arm.

Try less outhaul and possibly more downhaul. Try moving your harness lines further forward.

Ezzy Mast:

Does the Ezzy Freewave only work on Ezzy Skinny Masts?

No. The Freewave was designed to work on both skinny and regular diameter masts.

What is the advantage of using a skinny mast?

They are stronger, lighter and easier to maneuver.

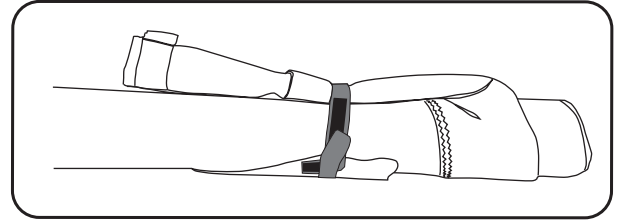

(figure 1)

After rolling, wrap the tack strap around the pad and sail.



(figure 2)

To avoid damaging your sail, insert the sail sleeve-end first into the bag.

SAIL	340 Top	340 Base	370 Top	370 Base	400 Top	400 Base	430 Top	430 Base
3.7		x	x					
4.2			x	x				
4.7					x	x		
5.2						x	x	
5.8							x	x
6.3							x	x

x = best combination
■ = good combination

(figure 3)

Suggested Masts

