



# Tuning Guide

## 1) Downhaul:

Observe the dots that are printed on the upper leech of your sail between battens #2 and #3.

As you increase your downhaul, the looseness travels from the dots closest to the edge of the leech to the forward dots that are closest to the luff.

- Light wind: downhaul until the leech looseness extends to the first set of dots that are closest to the edge of the leech (figure 1).

- Medium wind: the looseness should extend to the middle dots (figure 2).

- Strong wind: the looseness should extend to the forward dots (figure 3).

### Additional Information:

- Do not over-downhaul. The difference between the low-wind and high-wind downhaul settings is only 2.0 cm.

- If you feel over-powered, add more outhaul.

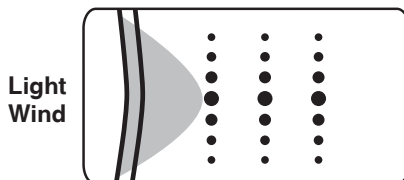
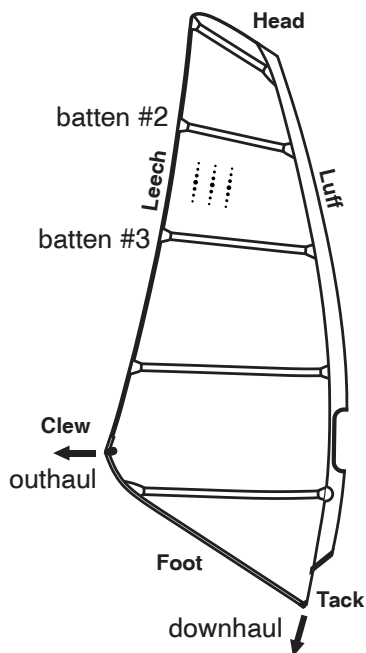

Figure 1: For light wind, downhaul to the first row of dots.

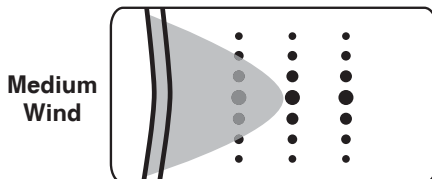

Figure 2: For medium wind, downhaul to the middle dots.

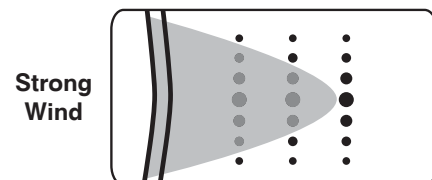

Figure 3: For strong wind, downhaul to the forward dots.

## 2) Setting the Outhaul:

The Legacy requires more positive outhaul than most sails (figure 4).

The three cords sewn at the clew indicate how much positive outhaul is needed for three wind conditions. The longest cord is for high wind, the shortest cord is for light wind and the middle cord is for medium wind.

### Follow these steps:

- a) Correctly set the downhaul.
- b) Release the outhaul tension completely.
- c) Gently pull on the outhaul cord and set your boom to the end of the cord (figure 5).
- d) Outhaul your sail to the end of the boom (figure 6).

### Additional Information:

- When setting your boom to the cord, don't pull the clew.
- We suggest starting with the medium length cord. If you feel over-powered (back-hand pressure), increase the outhaul about 1 to 2 cm. If you feel under-powered, reduce the outhaul by about 1 to 2 cm.

## 3) Tension the Tack Strap

After downhauling, thread the tack strap through the buckle and pull the strap until the foot gets tension. You will see a small wrinkle running out from the corner of the sail. Then, wrap the end of the tack strap around your mast extension and loop the end of the tack strap under itself and secure the strap with the velcro. Wrap your downhaul line around your extension (figure 7).

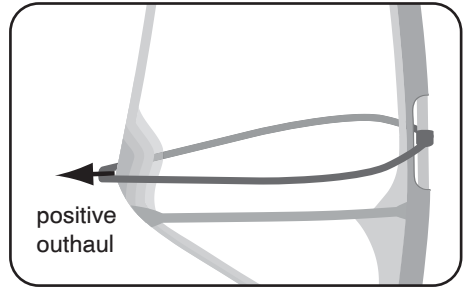

Figure 4: Positive outhaul

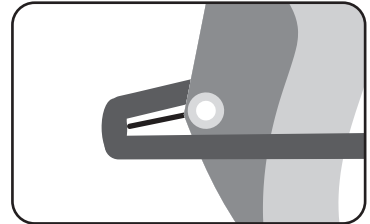

Figure 5: Set the boom length to the outhaul cord

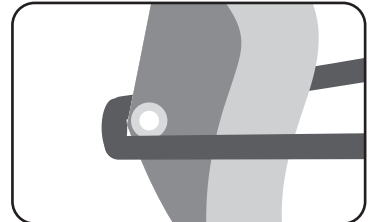

Figure 6: Outhaul sail to the end of the boom

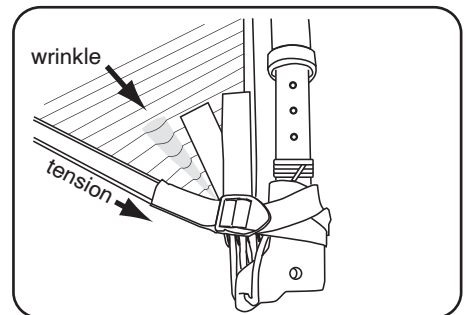

Figure 7: Tension tack strap

#### 4) Sail Care:

- Creasing damages the sail cloth. Avoid creasing your sail when rigging and de-rigging.
- Sunlight kills all sail cloth. Keep your sail out of the sun when not sailing.
- Don't rig on sharp objects.
- To hold the sail after rolling, wrap the tack strap around the sail, then attach the velcro (figure 8).
- Insert your sail sleeve-end first into the sail bag (figure 9).
- Never store your sail upright resting on the clew.
- Don't roll your sail when it is wet with fresh water. This will cause the window vinyl to turn hazy blue. Allow your sail dry thoroughly for the vinyl to clear up.

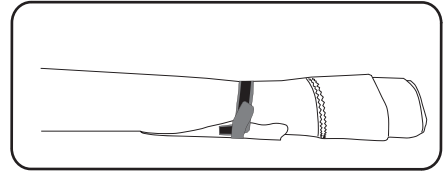

Figure 8 After rolling, wrap with the tack strap and secure the velcro.

#### 5) Troubleshooting:

> **Your sail has too much back-hand pressure.**

Solutions:

- Apply more outhaul,
- Check that your harness lines are not too far forward.

> **Your sail feels unstable.**

Solution:

Apply more downhaul and outhaul.

> **Your sail lacks power.**

Solution:

Reduce downhaul and outhaul.

> **Your sail has too much pressure on your front hand.**

Solutions:

- Reduce outhaul.
- Check that your harness lines are not too far back.



Figure 9: Sleeve end first into bag.

#### Correct Masts:

370	400	430	460
4.2			
	4.7		
	5.2		
		5.8	
		6.5	
			7.5

## 6) Not sure if you are getting the most out of your sail?

Simply snap a picture of your sail from the following perspective, and email it to [info@ezzy.com](mailto:info@ezzy.com) for our assessment.

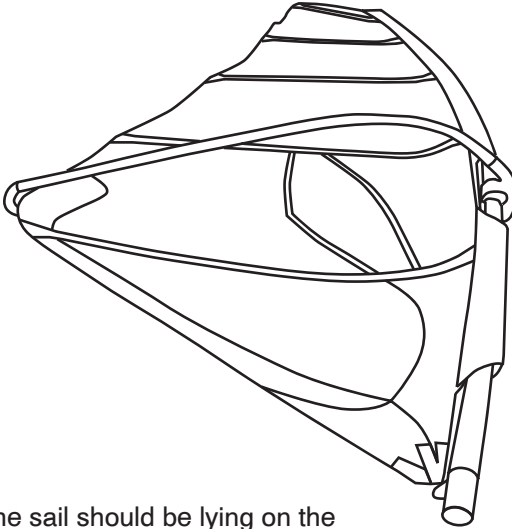

The sail should be lying on the ground (do not elevate the head).

## 7) Legacy accessory add-ons:

- 1) Mast pad
- 2) Tack pulley
- 3) Batten tensioner key
- 4) Head webbing extender for longer masts

You can purchase these at [www.ezzy.com](http://www.ezzy.com).

## Rigging Videos:

[www.ezzy.com](http://www.ezzy.com)

## Email:

[info@ezzy.com](mailto:info@ezzy.com)

## Call:

(800) 490-7436